

Technical Specifications

I49 Frame

74/98/135/195 - 120mm

English						Metric				
Injection Unit Specifications										
Injection Capacity, Max GPPS*	oz	74	98	135	195	gm	2,098	2,778	3,827	5,528
Theoretical Disp	in ³	133.2	178.3	243.8	357.0	cm ³	2,183	2,922	3,995	5,850
Injection Performance										
Max Pressure @ Rate		35,000 psi @ 31 in ³ /sec	30,000 psi @ 41 in ³ /sec	23,200 psi @ 56 in ³ /sec	17,763 psi @ 73 in ³ /sec		2,414 bar @ 508 cm ³ /sec	2,069 bar @ 672 cm ³ /sec	1,600 bar @ 917 cm ³ /sec	1,225 bar @ 1,196 cm ³ /sec
Max Rate @ Pressure		62 in ³ /sec @ 24,726 psi	82 in ³ /sec @ 18,752 psi	112 in ³ /sec @ 13,645 psi	146 in ³ /sec @ 10,447 psi		1,105 cm ³ / sec @ 1,705 bar	1,343 cm ³ / sec @ 1,281 bar	1,834 cm ³ / sec @ 941 bar	2,392 cm ³ / sec @ 720 bar
Max Injection Speed	in/sec	19	19	19	19	mm/sec	482	482	482	482
Max Pack Pressure	psi	35,000	30,000	23,200	17,763	bar	2,414	2,069	1,600	1,225
Max Pull Back Force	lbf	25,000	25,000	25,000	25,000	N	111,205	111,205	111,205	111,205
Plunger Stroke	in	40.75	40.75	40.75	40.75	mm	1,035	1,035	1,035	1,035
Plunger Diameter	in	2.04	2.36	2.76	3.34	mm	52	60	70	85
Extruder L/d Ratio - 120mm*						25				
Extruder RPM - Low Torque	rpm					160				
Extruder RPM - High Torque	rpm					130				
Barrel Heat										
No. of Pyrometers (barrel/nozzle)						10/1				
Total Heat Capacity	kw					142.75				
Sled Pull in Force	ton	4.1				tonf	3.7			
Clamp Specifications										
Tonnage	ton	935				tonf	850			
Maximum Daylight	in	94.49				mm	2,400			
Max/Min Mold Height	in	47.24/17.72				mm	1,200/450			
Max Mold Weight	lb	44,800				kg	20,235			
Max Clamp Stroke	in	47.24				mm	1,200			
Euromap Dry Cycle Time	sec					<5				
Platen Size	in	68.3 × 60.8				mm	1,735 × 1,545			
Tie Bar Spacing	in	49.21 × 39.37				mm	1,250 × 1,000			
Tie Rod Diameter	in	7.87				mm	200			
Ejector Stroke	in	10.8				mm	275			
Max Ejector Force**	ton	19.7				tonf	17.9			
Max Eject Speed**	in/sec	8.9				mm/sec	225			
Machine Specifications***										
Length, see note	in	484.2				mm	12,299			
Width	in	118.0				mm	2,997			
Height	in	108.7				mm	2,761			
Centerline Height	in	58.0				mm	1,473			
Shipping Weight (machine)	lb	94,000/31,000/125,000				kg	42,637/14,061/56,669			
Electrical Specifications***										
Input Power Source 460 VAC ± 10% 3 Ph 60 Hz						Std.				
Power Supply Capacity kVA						190				
Machine Requirements										
Water						6 gpm @ 80 psi				
Air						80 psi @ 20 cfm				

*Note: Other capacities available. Please Consult Factory.

**Note: Higher eject force and speed available. Please Consult Factory.

***Note: All machine dimensions and specifications are subject to change. Values are for reference only.

Technical Specifications

I45 Frame

72/96/130 - 70mm

		English			Metric			
Injection Unit Specifications		A	B	C		A	B	C
Injection Capacity, Max GPPS*	oz	72	96	130	gm	2,041	2,722	3,685
Theoretical Disp	in ³	134.1	178.6	243.1	cm ³	2,198	2,927	3,984
Injection Performance								
Max Pressure @ Rate		30,000 psi @ 18.4 in ³ /sec	23,200 psi @ 24.5 in ³ /sec	17,000 psi @ 36.9 in ³ /sec	bar	2,069 bar @ 302 cm ³ /sec	1,600 bar @ 401 cm ³ /sec	1,172 bar @ 605 cm ³ /sec
Max Rate @ Pressure		48.5 in ³ /sec @ 15,200 psi	64.6 in ³ /sec @ 11,440 psi	87.9 in ³ /sec @ 8,400 psi	cm ³ /sec	795 cm ³ /sec @ 1,048 bar	1,059 cm ³ /sec @ 789 bar	1,440 cm ³ /sec @ 580 bar
Max Injection Speed	in/sec	14.75	14.75	14.75	mm/sec	375	375	375
Max Pack Pressure	psi	30,000	23,200	17,000	bar	2,069	1,600	1,172
Max Pull Back Force	lbf	25,000	25,000	25,000	N	111,205	111,205	111,205
Plunger Stroke	in	40.75	40.75	40.75	mm	1,035	1,035	1,035
Plunger Diameter	in	2.04	2.36	2.76	mm	52	60	70
Extruder L/d Ratio - 70mm						30		
Extruder RPM - Low Torque	rpm					265		
Extruder RPM - High Torque	rpm					265		
Barrel Heat								
No. of Pyrometers (barrel/nozzle)						10/1		
Total Heat Capacity	kw					65.26		
Sled Pull in Force	ton		4.1		tonf		3.7	

Clamp Specifications					
Tonnage	ton	935		tonf	850
Maximum Daylight	in	94.49		mm	2,400
Max/Min Mold Height	in	47.24/17.72		mm	1,200/450
Max Mold Weight	lb	44,800		kg	20,325
Max Clamp Stroke	in	47.24		mm	1,200
Euromap Dry Cycle Time	sec				<5
Platen Size	in	68.3 × 60.8		mm	1,735 × 1,545
Tie Bar Spacing	in	49.21 × 39.37		mm	1,250 × 1,000
Tie Rod Diameter	in	7.87		mm	200
Ejector Stroke	in	10.8		mm	275
Max Ejector Force**	ton	19.7		tonf	17.9
Max Eject Speed**	in/sec	8.9		mm/sec	225

Machine Specifications***					
Length, see note	in	484.2		mm	12,299
Width	in	118.0		mm	2,997
Height	in	108.7		mm	2,761
Centerline Height	in	58.0		mm	1,473
Shipping Weight (machine)	lb	94,000/31,000/125,000		kg	42,637/14,061/56,699

Electrical Specifications***			
Input Power Source 460 VAC ± 10% 3 Ph 60 Hz			Std.
Power Supply Capacity kVA			190

Machine Requirements			
Water			6 gpm @ 50 psi
Air			80 psi @ 20 cfm

*Note: Other capacities available. Please Consult Factory.

**Note: Higher eject force and speed available. Please Consult Factory.

***Note: All machine dimensions and specifications are subject to change. Values are for reference only.

Technical Specifications

I78 Hybrid Frame

38/44/50 - 120mm

		English				Metric		
Injection Unit Specifications		A	B	C		A	B	C
Injection Capacity, Max GPPS	oz	38	44	50	gm	1,077	1,247	1,417
Theoretical Disp	in ³	68.9	80.1	91.5	cm ³	1,129	1,313	1,500
Injection Performance								
Max Pressure	psi	34,800	30,000	27,500	bar	2,400	2,069	1,897
Max Rate	in ³ /sec	153	175	200	cm ³ /sec	2,500	2,868	3,278
Max Injection Speed	in/sec	30	30	30	mm/sec	762	762	762
Max Pack Pressure	psi	27,840	24,000	22,000	bar	1,920	1,655	1,518
Max Pull Back Force	lbf	22,000	22,000	22,000	N	97,860	97,860	97,860
Plunger Stroke	in	13.39	13.39	13.39	mm	340	340	340
Plunger Diameter	in	2.56	2.76	2.95	mm	65	70	75
Extruder L/d Ratio - 120mm*						25		
Extruder RPM - Low Torque	rpm					160		
Extruder RPM - High Torque	rpm					130		
Barrel Heat								
No. of Pyrometers (barrel/nozzle)						11/1		
Total Heat Capacity	kw					148.3		
Sled Pull in Force	ton		12		tonf		10.8	

Clamp Specifications					
Tonnage	ton		935	tonf	850
Maximum Daylight	in		94.49	mm	2,400
Max/Min Mold Height	in		47.24/17.72	mm	1,200/450
Max Mold Weight	lb		44,800	kg	20,325
Max Clamp Stroke	in		47.24	mm	1,200
Euromap Dry Cycle Time	sec				<5
Platen Size	in		68.3 × 60.8	mm	1,735 × 1,545
Tie Bar Spacing	in		49.21 × 39.37	mm	1,250 × 1,000
Tie Rod Diameter	in		7.87	mm	200
Ejector Stroke	in		10.8	mm	275
Max Ejector Force (hyd std)**	ton		19.7	tonf	17.9
Max Eject Speed**	in/sec		20	mm/sec	510

Machine Specifications***					
Length	in		484.2	mm	12,299
Width	in		118.0	mm	2,997
Height	in		108.7	mm	2,761
Centerline Height	in		58.0	mm	1,473
Shipping Weight (machine)	lb		94,000/31,000/125,000	kg	42,637/14,061/56,699
Shipping Weight (power unit)	lb		3,800	kg	1,724

Electrical Specifications***			
Input Power Source 460 VAC ± 10% 3 Ph 60 Hz			Std.
Power Supply Capacity kVA			217

Machine Requirements			
Water			15 gpm @ 85 F
Air			80 psi @ 20 cfm

*Note: 70mm 30:1 L/d extruder also available (consult factory)

**Note: Higher eject force and speed available (consult factory)

***Note: All machine dimensions and specifications are subject to change. Values are for reference only.

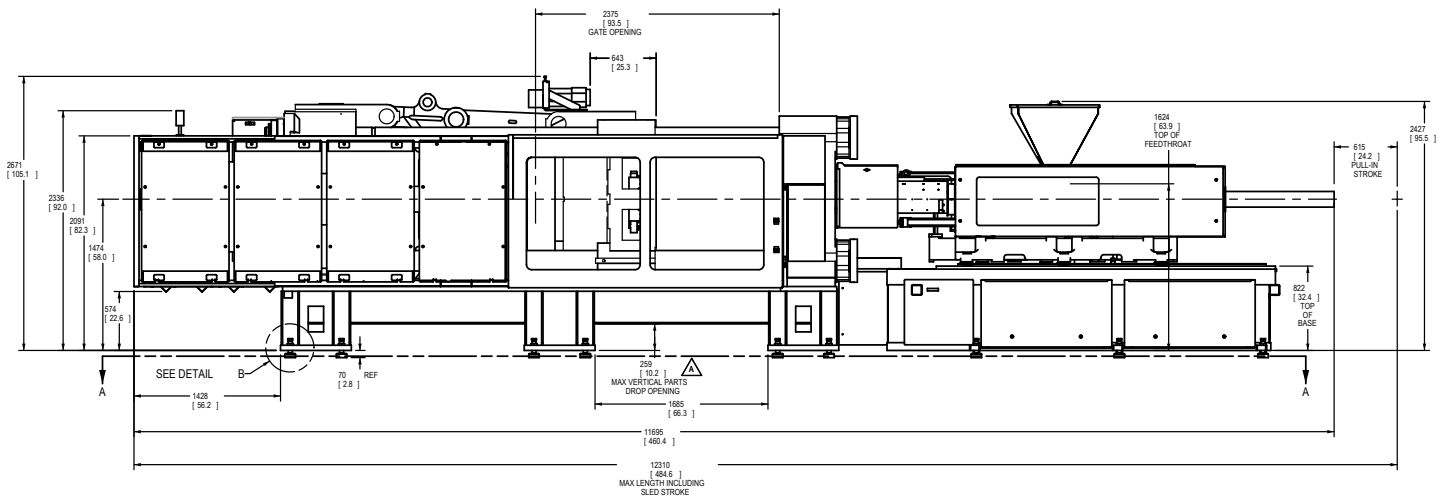
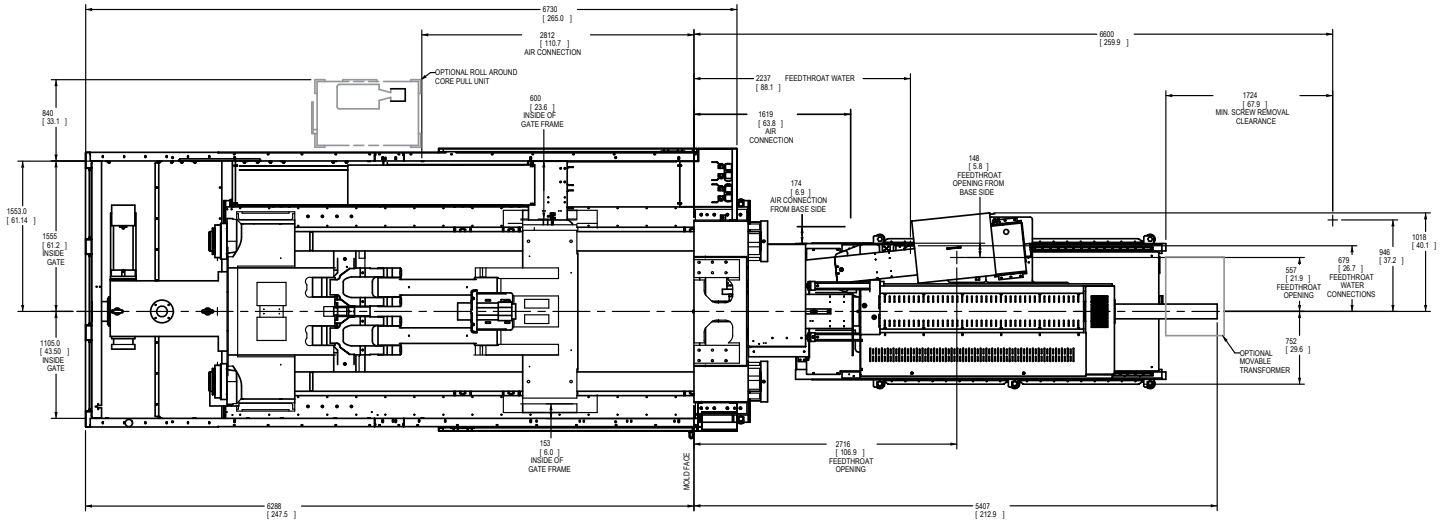

935 Templates

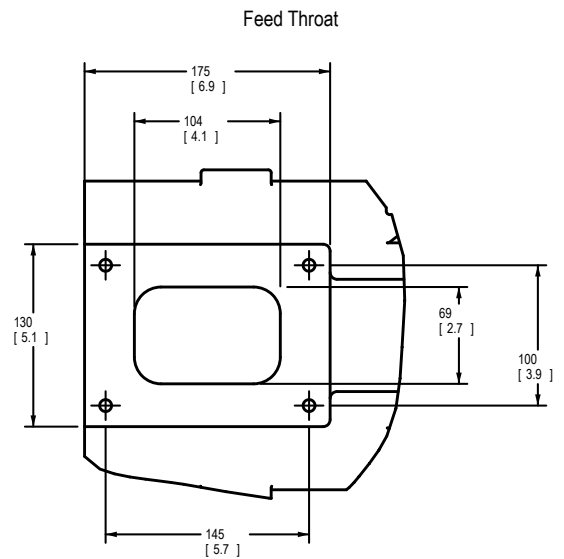
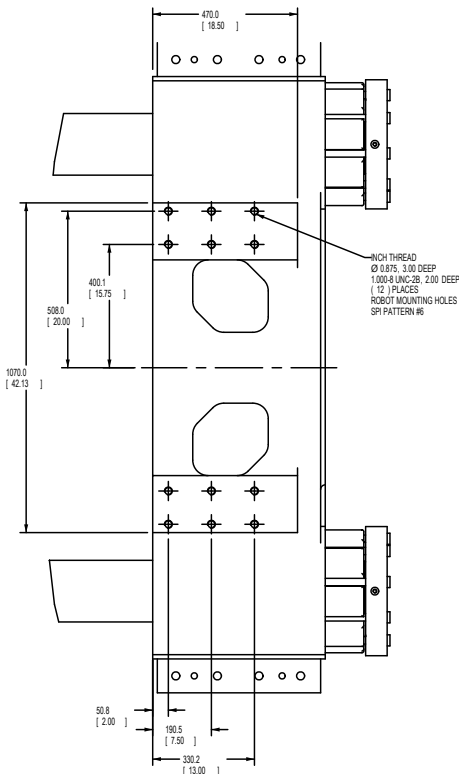
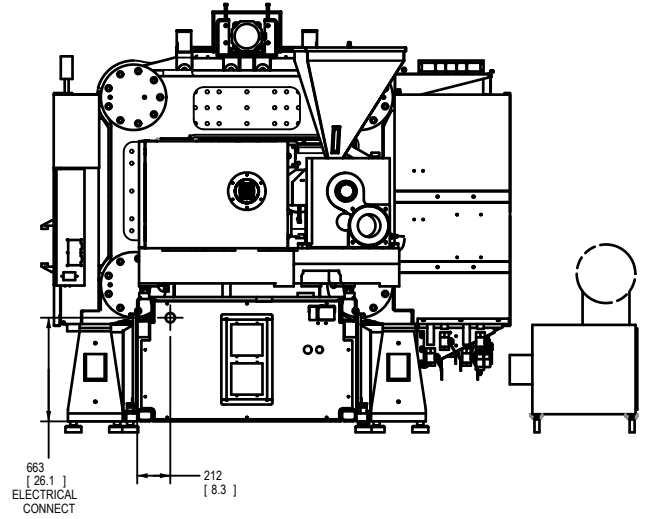
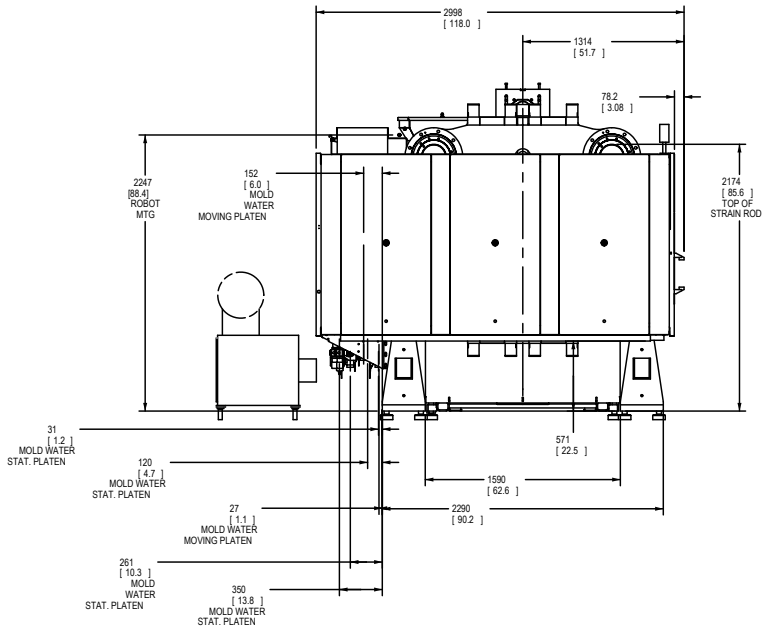

Feed throat dimensions can change based on injection frame.
 Consult factory for specific details.

935 Templates

